

# Comparison of 3D Finite Element Slope Stability With 3D Limit Equilibrium Analysis

## Comparaison de la stabilité des éléments 3D pente finie avec l'analyse limite d'équilibre 3D

Lu H.H., Xu L.M., Fredlund M.D.  
SoilVision Systems Ltd., Saskatoon, SK., Canada

Fredlund D.G.  
Golder Associates Ltd., Saskatoon, SK., Canada

**ABSTRACT:** The two-dimensional (2D) limit equilibrium analysis is widely used in geotechnical engineering for slope stability analysis. Three-dimensional (3D) slope stability analysis is rarely performed although all slope failures are 3D in reality. The 3D shear strength reduction (SSR) technique using finite element method (FEM) analysis and 3D limit equilibrium method (LEM) based on columns to predict a factor of safety for slopes have been in existence for decades. Recent software tools allow the improved analysis of 3D slope stability through LEM and SSR techniques. The purpose of this paper is primarily to compare 3D FEM-SSR analysis with 3D LEM analysis through the examination of benchmark slope stability analysis examples. The results indicate that there is reasonable agreement between these two methods.

**RÉSUMÉ :** L'analyse d'équilibre limite en deux dimensions (2D) est la méthode d'analyse de stabilité des pentes la plus couramment utilisée en géotechnique. L'analyse de stabilité des pentes en trois dimensions (3D) est rarement effectuée bien que tous les glissements de terrain sont en réalité tridimensionnels. La technique de la réduction de résistance au cisaillement (SSR) en 3D utilisant la méthode des éléments finis (FEM), ainsi que l'analyse d'équilibre limite (LEM) en 3D basée sur des colonnes pour prédire un facteur de sûreté pour des pentes, existent depuis des décennies. Les codes de calcul récents permettent d'améliorer l'analyse de stabilité des pentes en 3D à l'aide des techniques de LEM et de SSR.

Le but de cet article est principalement de comparer l'analyse de FEM-SSR en 3D avec l'analyse de LEM en 3D à travers des exemples de référence d'analyse de stabilité. Les résultats indiquent qu'il y a un accord raisonnable entre ces deux méthodes.

**KEYWORDS:** 3D Slope Stability Analysis, Shear Strength Reduction, Limit Equilibrium Method, Finite Element Method.

### 1 INTRODUCTION

The 2D LEM is widely used in geotechnical engineering for slope stability analysis. However all slope failures are 3D in reality. The 2D approach is generally considered to be conservative in that 3D influences of geometry are not accounted for in a 2D analysis. Furthermore, the assumption that 2D analyses lead to conservative factors of safety is correct only when the critical pessimistic section of the 3D model is selected for the 2D analyses. It is time consuming to ensure that the 2D section model is the critical pessimistic 2D section for some general slopes. The use of 3D slope stability analysis is important to model real world problems, to make the designs more economic, and to provide a guide for 2D designs. It is useful, for example, to know exactly what percentage the 3D FOS is higher than the 2D analysis. The most common methods for 3D slope stability analysis are 3D LEM based on columns and 3D SSR based on FEM analysis.

#### 1.1 3D LEM slope stability analysis

3D LEM slope stability analysis is traditionally based on an extension of 2D LEM analysis. Many researchers have done work on 3D LEM analysis (Hovland 1977, Hungr, Zhang 1988, Salgado and Byrne 1989, Lam and Fredlund 1993, Cheng, etc. 2005). The slicing method in 2D analyses has been extended into 3D analysis with columns by various authors due to the popularity of 2D LEM slicing methods. Some of the benefits of the 2D slicing method include its ability to accommodate complex geometries, variable soils, water pressure conditions and different reinforcement systems, etc..

The majority of the 3D LEMs are based on the assumption that the failure direction is pre-defined in order to derive the FOS equations, i.e. the failure sliding direction is not part of the slope stability analysis solution. Location of the critical failure surface and its direction is a tough global optimization problem.

Jiang (1997), Yamagami and Jiang (1997) provided a optimization-minimization procedure (OMP) for their Dynamic Programming (DP) (Baker, 1980) and random number generation technique to find the critical slip surface and corresponding sliding direction. Cheng and Yip (2003) derived 3D asymmetric slope stability analysis equations based on extensions of simplified Bishop, simplified Janbu and Morgenstern-Price methods, and the direction of slide can be determined from 3D force/moment equilibrium equations. Their formulation is equivalent to Yamagami and Jiang's OMP.

SoilVision Systems Ltd. (SVS) has incorporated all the popular 3D LEMs into its commercial 3D slope stability analysis software - SVSLOPE 3D. Recently SVS has added a new feature to search for the critical slip surface sliding direction in 3D, which is similar to Jiang (1997)'s procedure. This feature enables the modeling of 3D slopes by the LEM at any angle and is applicable for municipal designs including calculation of setback distances as well as the stability of open pits in the mining industry as well as other applications.

#### 1.2 3D FEM-SSR slope stability analysis

The finite element method (FEM) has been extensively used to analyze various geotechnical problems. To perform slope stability analysis with the FEM, the SSR technique dictates that the soil shear-strength is gradually reduced until failure conditions occur. The factor of safety (FOS) for a SSR analysis is defined as the ratio of the shear strength of the soil to the shear stress developed along the critical failure surface. This relationship is presented in the following equations.

$$\begin{aligned}c_f &= c / SRF \\ \phi_f &= \tan^{-1}(\tan \phi / SRF)\end{aligned}$$

where  $c$  and  $\phi$  are the cohesion and angle of internal friction for the Mohr-Coulomb shear strength parameters.  $c_f$  and  $\phi_f$  are factored shear strength parameters.  $SRF$  is called the strength reduction factor. In order to reach to the state of limiting

equilibrium, the *SRF* is gradually increased. This means that the soil shear strength becomes weaker, until it is no longer possible for the FE model analysis to reach convergence. At this stage, it can be said that failure of the slope occurs and the FOS equals the *SRF*. Non-convergence within a specified number of iterations and tolerance is an indicator of slope failure because of the absence of force equilibrium (i.e. stress and displacement distributions that satisfy the equations of equilibrium cannot be established based on the factored set of shear strength parameters).

The FEM-SSR analysis has been shown to be a powerful and a useful alternative to conventional LEM slope stability analysis technique, Griffiths *et al* (1999, 2007), Wei, etc. (2009). SoilVision Systems Ltd. has incorporated the 3D FEM-SSR into its commercial package - SVSOLID 3D. Consequently, the 3D FEM-SSR is now readily available to geotechnical engineering practice.

## 2 EXAMPLES

### 2.1 Example 1 - 3D slope with external load

Wei, Cheng and Li (2009) considered a slope with a rectangle area of vertical external loading in order to show a distinct 3D failure surface. As shown in Figure 1, the vertical distribution loading length is 8m and width is 2m, while in Wei, etc. (2009) many different combinations of length and width were considered. The edge of the loading is 1m away from the crest of the slope. The magnitude of the distribution load *q* is equal to 100 kPa. The soil shear strength properties are cohesion of 20 kPa, an angle of internal friction of 20 degrees and a unit weight of 20 kPa. Table 1 shows the results of the various analyses. Figure 2 and Figure 3 clearly show the distinct 3D failure surface based on a FEM-SSR analysis. Figure 4 shows the critical slip surface based on a 3D LEM analysis. It can be seen that both the failure slip surface shape and FOS values from the FEM-SSR result and the 3D LEM result match well with the Wei et al. (2009) result.

Table 1. Comparison of 3D FOS for the slope in Example 1

SVSLOPE3D (LEM)	SVSOLID3D (SSR)	Wei, etc (2009) (SSR)
1.359	1.402	1.42

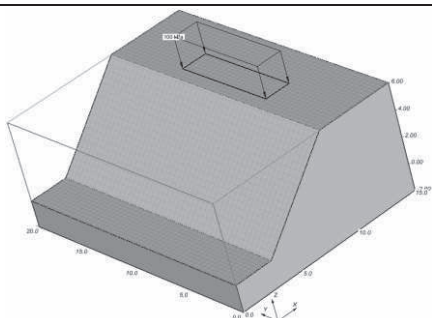

Figure 1. The geometry of the slope with external load in SVSLOPE 3D

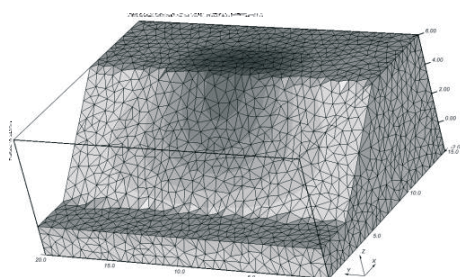

Figure 2. Contour of total displacement of 3D FEM-SSR analysis for example 1 at the final stage.

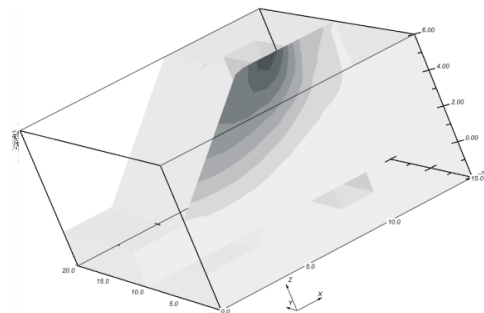

Figure 3. Y-section view of the contour of the total displacement for example 1

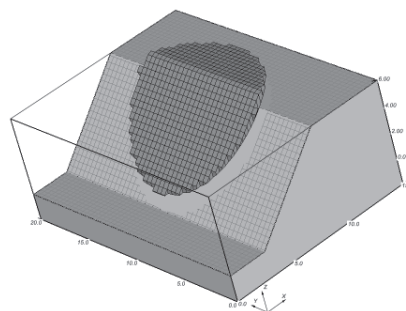

Figure 4. Critical slip mass of the 3D LEM analysis with explosive view for example 1

### 2.2 Example 2 - A nonsymmetrical slope with corners

One of the advantages of the 3D FEM-SSR analysis is that the sliding direction does not need to be specified in advance. A limitation for 3D column-based LEMs is that the sliding direction of the critical slip surface is another variable which must be determined through a searching procedure. A new feature has been added in SVSLOPE 3D to search for the critical slip surface direction with optimization. There is continued usefulness in the LEM because of its computational efficiency. Computational times for FEM-SSR methods are significantly higher than for LEM analysis. This efficiency is particularly useful in performing a 3D analysis when the number of computations is significantly increased. The purpose of this example is to test the efficiency of both 3D FEM-SSR slope stability analysis and 3D LEM slope stability analysis for general slopes without evident sliding direction information available.

In this example, a general asymmetrical slope with inclined corners is considered. As shown in Figure 5 and Figure 6, there are three slopes with different inclinations, the right slope's inclination is 1:2, the left slope's inclination is 1:1.5 and the middle slope's inclination is 1:1.3 respectively. This model is digitized from Jiang (1997). The soil's Mohr-Coulomb shear strength parameters are a cohesion of 5 kPa and an angle of internal friction of 12 degrees.

Table 2 shows the comparison from different analysis results. Jiang (1997) shows a FOS = 0.96 based on 3D Simplified Janbu method with DP searching. The FOS from FEM-SSR analysis is 0.941. The contour of the final displacement at the final stage is shown in Figure 7. The critical slip mass based on 3D LEM analysis is shown in Figure 6. The FOS is 0.957 and 0.977 separately for Simplified Bishop and Spencer method. The critical slip direction also needs to be found. As shown in Figure 8, the critical slip surface direction is 43 degree counter-clock wise from the negative x direction. It can be seen clearly that both the shape and slip direction are

very close between the FEM-SSR analysis and the LEM analysis as seen in Figure 6 and Figure 7.

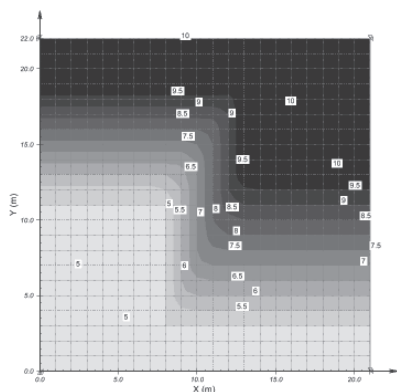

Figure 5. Plan view of elevation contour of Example 2

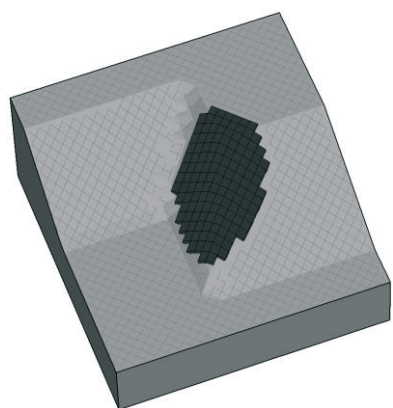

Figure 6. Critical slip mass of Example 2 from the 3D LEM analysis

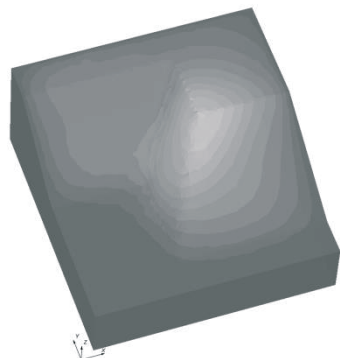

Figure 7. Contour of total displacement from FEM-SSR analysis

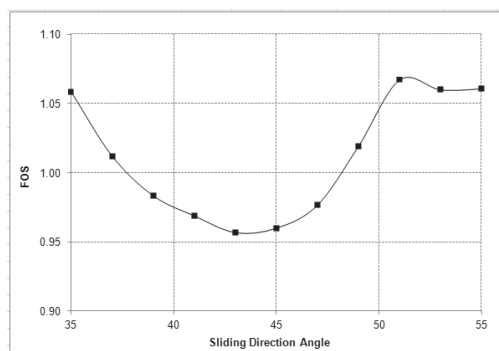

Figure 8. Plot of rotation angle vs. FOS for Example 2

Table 2. Comparison of 3D FOS for the slope in Example 2

SVSLOPE3D (LEM)	SVSOLID3D (SSR)	Jiang( 1997) (LEM+DP)
0.957 (Bishop), 0.977 (Spencer)	0.941	0.96

### 3 CONCLUSIONS

An actual slope failure occurs along the most critical sliding direction that is often unknown for general 3D slopes. Determination of the critical slip surface and its FOS involves the search for the critical sliding direction. One of the advantage of FEM-SSR technique is that it does not need to specified the sliding direction in advance, however it can not give the exact sliding direction angle value either. SVSLOPE 3D provides an optimizatoin technique that can find the critical sliding direction as part of FOS search.

Based on Example 1 it can be seen that both the failure slip surface shape and FOS values from the FEM-SSR result and the 3D LEM result match well with the Wei et al. (2009) result. The second example also demonstrates the similarity of results between analyzing a complex 3D slope stability geometry where the direction of the slip may have an effect on the calculated FOS.

These results demonstrate the usefulness of both 3D LEM and FEM-SSR methodologies for the analysis of slope geometries and loading conditions which are fundamentally 3D in nature.

### 4 REFERENCES

- Baker R. 1980. Determination of the critical slip surface in slope stability computations. *Int. J. for Numerical and Analytical Methods in Geomechanics*, 4, 333-359.
- Cheng Y.M. 2003. Locations of critical failure surface and some further studies on slope stability analysis. *Computers and Geotechnics* 30 (3), 255-267.
- Cheng Y.M., Liu H.T., Wei W.B. and Au S.K. 2005. Location of critical three-dimensional non-spherical failure surface by NURBS functions and ellipsoid with applications to highway slopes. *Computers and Geotechnics* 32 (6), 387-399.
- Griffiths D.V. and Lane P.A. 1999. Slope stability analysis by finite elements. *Géotechnique*, 49 (3), 387-403.
- Griffiths D.V. and Marquez R.M. 2007. Three-dimensional slope stability analysis by elasto-plastic finite elements. *Géotechnique*, 57 (6), 537-546.
- Hovland H.J. 1977. Three-dimensional slope stability analysis method. *J Geotech Eng Div, ASCE* 103 (9), 971-986.
- Hungr O., Salgado F.M. and Byrne P.M. 1989. Evaluation of a three-dimensional method of slope stability analysis. *Canadian Geotechnical Journal*, 26 (4), 679-686.
- Jiang J.C. 1997. Determination of the three-dimensional critical slip surface in slope stability analysis, *PhD thesis*, the University of Tokushima, Tokushima, Japan.
- Lam L. and Fredlund D.G. 1993. A general limit equilibrium model for three-dimensional slope stability analysis. *Canadian Geotechnical Journal*, 30 (6), 905-919.
- Wei W.B., Cheng Y.M. and Li L. 2009. Three-dimensional slope failure analysis by the strength reduction and limit equilibrium methods. *Computers and Geotechnics*, 36 (1-2), 70-80.
- Yamagami T. and Jiang J.C. 1997. A search for the critical slip surface in three dimensional slope stability analysis. *Soils and Foundation* 37 (3), 1-6.
- Zhang X. 1988. Three-dimensional stability analysis of concave slopes in plan view. *J. Geotech. Engng, ASCE*, 114 (6), 658-671.