

# General Report of TC 106 Unsaturated soils

Rapport général du TC 106  
Sols non saturés

Jommi C.

*Department of Geoscience and Engineering, Delft University of Technology, Delft, The Netherlands*

*Department of Civil and Environmental Engineering, Politecnico di Milano, Milano, Italy*

**ABSTRACT:** This general report summarises the contributions on unsaturated soil mechanics submitted to the Discussion Session of TC106 – Unsaturated soils – at the 18<sup>th</sup> International Conference on Soil Mechanics and Geotechnical Engineering held in Paris in September 2013. The thirty-five papers collected under the framework of unsaturated soil mechanics cover a broad spectrum of problems and procedures at varying scales. Much attention is devoted to issues related to experimental techniques and procedures for hydro-mechanical characterisation of unsaturated soils, with special attention to retention behaviour. Swelling, shrinkage and eventually cracking are the processes which seem to capture most of the attention in view of the performance of engineering systems. A few contributions deal with constitutive and numerical approaches, while only a couple of papers introduce unsaturated soil mechanics into engineering practice. While innovative efforts are mainly addressed to experimental techniques in the laboratory, the most challenging issues in future perspective appear to be related to the assessment of unsaturated geotechnical systems in the field, including contaminated soils and mine tailings, besides to more traditional applications dealing with compacted soil structures and soil-atmosphere interaction.

**RÉSUMÉ :** Ce rapport général résume les contributions sur les sols non saturés soumis à la Session de Discussion du TC106 - Sols non saturés - du 18<sup>ème</sup> Congrès International de Mécanique des Sols et de Géotechnique tenu à Paris en Septembre 2013. Les trente cinq articles collectés couvrent un large spectre de problèmes et de procédures à des échelles variées. Beaucoup d'attention est portée aux aspects concernant les techniques expérimentales et les procédures de caractérisation hydro-mécanique des sols non saturés, avec une attention spéciale pour les propriétés de rétention. Le gonflement, le retrait et la fissuration sont les problèmes qui semblent les plus étudiés dans les applications géotechniques. Quelques contributions concernent les approches constitutives et numériques, alors que seulement une paire d'articles introduit la mécanique des sols non saturés dans la pratique. Alors que des efforts novateurs concernent principalement l'évaluation des techniques expérimentales dans le laboratoire, le défi des prochaines années semble concerner l'évaluation des systèmes non saturés sur le terrain, incluant les sols contaminés et les résidus, en plus des applications plus traditionnelles liées aux structures en sol compacté et aux interactions entre le sol et l'atmosphère.

**KEYWORDS:** unsaturated soils, laboratory and field testing, hydro-mechanical behaviour, assessment of geo-engineering systems

## 1 INTRODUCTION.

The number of papers presented to the Discussion Session organised by the Technical Committee TC106 testifies the interest of the geotechnical community in geo-engineering problems related to unsaturated conditions. Papers on a broad spectrum of aspects of unsaturated soils behaviour, coupled hydro-mechanical processes, laboratory developments, field and laboratory experimental techniques, and geotechnical problems have been submitted. Researchers from all the continents contribute to the session, although most of them come from Europe, Asia – with the relevant participation of Japan with six papers – and North America.

The thirty-five papers submitted to the Discussion Session are summarised in Table 1, where a list of selected keywords tries to provide a first glance on the topics which are capturing most of the attention at present. It appears that lot of effort is addressed to the hydraulic characterisation of unsaturated soils, especially for what concerns experimental techniques and procedures for the description of water retention behaviour, at increasing scale, from the laboratory to the field and possibly the regional scale. It might be argued that the first season of unsaturated soil mechanics, in which the attention has been focussed almost exclusively on the role of suction on the mechanical behaviour of unsaturated soils, has come to an end. The contributions presented to this conference suggest that the mutual influence between the hydraulic history, in terms of both suction and a measure of the amount of water retained in the pores, and the strain history of the soil is considered of

paramount importance to understand and describe the peculiar features of geo-engineering problems related to unsaturated soils.

The hydro-mechanical behaviour of compacted soils is still under investigation, both in static and dynamic conditions, together with improvement techniques. Theoretical and constitutive approaches are being evaluated as an extension to unsaturated conditions of approaches previously conceived for saturated soils. Coupled thermo-hydro-mechanical finite element formulations are being consistently used, both to assess the performance of new hydro-mechanical models, and to predict the response of engineering systems.

Problems which have accompanied the history of unsaturated soil mechanics, like constructions on expansive soils or slope stability under rainfall infiltration, still deserve some attention. Studying the conditions leading to cracking and proper tracking and modelling of the cracking process is the present challenge for unsaturated soils undergoing significant volume changes, especially in view of climate changes. To this end, the effects of vegetation on the behaviour of upper soil horizons are being studied, to provide simple but effective models for water balance and vertical displacements, accounting for soil properties. Future challenges also come from fields related to environmental geotechnics, like mine tailings and waste repositories, where unsaturated soil mechanics is starting to be exploited in a consistent way.

Table 1. Synoptic table of contributions to the Discussion Session of TC 106 (WRC = water retention characteristics, FEM = finite element modelling)

<i>Authors</i>	<i>Country</i>	<i>Title of the paper</i>	<i>Selected Keywords</i>
Carrillo-Gil & Carrillo-Acevedo	Peru	Evaluation curves SWCC for tropical Peruvian soils	in situ WRC, tropical soils, modelling
Sugii <i>et al.</i>	Japan	Measurement of unsaturated ground hydraulic properties using a dynamic state soil moisture distribution model	in situ WRC, hydraulic conductivity
Maček <i>et al.</i>	Slovenia	Extension of measurement range of dew-point potentiometer and evaporation method.	WRC, dew-point potentiometer, evaporation method
Reis <i>et al.</i>	Brazil	Determination of soil-water retention curve for a young residual soil using a small centrifuge	WRC, centrifuge technique
Nishimura	Japan	Application of micro-porous membrane technology for measurement of soil-water characteristic curve	WRC, pressure membrane
Toll <i>et al.</i>	UK	New devices for water content measurement	resistivity, TDR, water content
Mendes & Toll	UK	Influence of initial water content on the water retention behaviour of a sandy clay soil	WRC, filter paper, scanning curves
Fredlund & Zhang	Canada	Combination of shrinkage curve and soil-water characteristic curves for soils that undergo volume change as soil suction is increased	WRC, volume change, property functions
Mukunoki & Mikami	Japan	Study on the mechanism of two-phase flow in porous media using X-ray CT image analysis	X-ray CT, multiphase flow
Schaefer & Birchmier	USA	Mechanisms of strength loss during wetting and drying of Pierre shale	shale, residual friction, weathering
Bai <i>et al.</i>	China	Experimental study on effect of initial moisture content of compressive property of compacted loess like silt	compaction, loess silt, compression
Mavroulidou <i>et al.</i>	UK	Hydro-mechanical properties of lime-treated London clay	lime treated, hydro-mechanical behaviour
Vázquez <i>et al.</i>	Spain	A simplified model for collapse using suction controlled tests	collapse, modelling
Byun <i>et al.</i>	Korea	Evaluation of void ratio and elastic modulus of unsaturated soil using elastic waves	elastic waves, void ratio, saturation, suction
Georgetti <i>et al.</i>	Brazil	Small-strain shear modulus and shear strength of unsaturated clayey sand	bender elements, shear modulus and strength
Hoyos <i>et al.</i>	USA	Dynamic shear modulus and damping of compacted silty sand via suction-controlled resonant column testing	resonant column, shear modulus, damping
Zhao <i>et al.</i>	China	Critical state for unsaturated soils and steady state of thermodynamic process	critical state, thermodynamics
Fathalikhani & Gatmiri	Iran	Numerical study of damage in unsaturated bentonite with $\theta$ -stock finite element code	FEM, damage, THM coupling
Kawai <i>et al.</i>	Japan	Expression of mechanical characteristics in compacted soil with soil/water/air coupled F.E. simulation	coupled FEM, compaction
Droniuc	France	Étude par la méthode des éléments finis du comportement des remblais en sols fins compactés	FEM, embankments, compacted soil
Sakai & Nakano	Japan	Interpretation of the effect of compaction on the mechanical behaviour of embankment materials based on the soil skeleton structure concept	FEM, embankment, compaction
Makki <i>et al.</i>	France	Effet du retrait du sol sur une maison expérimentale	masonry house, FEM, shrinkage,
Heyerdahl <i>et al.</i>	Norway	Rainfall-induced collapse of old railway embankments in Norway	stability, railway
Bajwa & Simms	Canada	Evolution of microstructure during desiccation of oil sands mature fine tailings	tailings, polymer, microstructure
MacRobert	South Africa	Field capacity and moisture loss during active deposition on tailing dams	tailings, field capacity, moisture loss
Siemens <i>et al.</i>	Canada	Effect of confining stress on the transient hydration of unsaturated GCLs	GCL, hydration, parametric study
Mitchell	Australia	Climate change effects on expansive soil movements	climate, expansive soils
Liu & Yasufuku	Japan	A geotechnical countermeasure for combating desertification	desertification
Hemmati & Modaressi	France	Etude de la stabilité des pentes non saturées sous les effets de l'infiltration prenant en compte la végétation	slope stability, root water uptake
Ng <i>et al.</i>	Hong Kong	Soil suction induced by grass and tree in an atmospheric-controlled plant room	vegetation, leaf area index, root area index
Adem & Vanapalli	Canada	A simple approach for predicting vertical movements of expansive soils using the mechanics of unsaturated soils	expansive soils, vertical displacements
Ejjaaouani <i>et al.</i>	Maroc	Comportement des sols gonflants lors de l'humidification et du séchage	swelling, shrinkage
Stanciu <i>et al.</i>	România	Soil chart, new evaluation method of the swelling-shrinkage potential, applied to the Bahlui's clay stabilized with cement.	swelling, ecologic cement stabilisation
Auvray <i>et al.</i>	France	Etude de l'impact de l'hygrométrie sur la fissuration d'un sol gonflant	cracking, image processing
Ávila <i>et al.</i>	Colombia	One-dimensional cracking model in clayey soils	cracking, modelling

## 2 HYDRAULIC BEHAVIOUR, RETENTION PROPERTIES AND FLOW

Nearly one third of the papers submitted to the Discussion Session deal with retention and flow properties, hence recognising the role of hydraulic state variables on the coupled hydro-mechanical response of unsaturated soil systems.

Characterisation of the retention properties is tackled at different scales. *Carrillo-Gil & Carrillo-Acevedo* (Peru) summarise 20-years data and models at regional scale for tropical Peruvian soils in the Amazon region (Fig. 1). Both correlations based on soil index properties and experimental data from suction cells are analysed, to provide a general view of the retention properties of three classes of soils (clayey – silty– sandy) coming from five different regions.

When the regional scale is analysed, only results for water content are given, irrespective of hysteresis of the soil water retention mechanisms, of the void ratio and of the hydraulic path, hence disregarding the coupled evolution of volumetric strain and water content. The estimated water retention curves (WRC) typically give wide ranges of water content for given suction, although typical patterns can be identified for the different soil classes (Fig. 2). As it is often the case, silty soils are the most difficult to be uniquely characterised, due to wider differences in plasticity, void ratios and fabric of the silty soils. Differences come from both heterogeneity of the soil properties and different initial void ratios. Attempts to preliminary characterisation of retention properties at the regional scale may be of relevant use for risk mapping. Hopefully, similar databases should be enriched in the future, and possibly re-analysed by means of statistical tools, to fully exploit their potentialities.



Figure 1. Regional scale for hydraulic characterisation of tropical Peruvian soils (*Carrillo-Gil & Carrillo-Acevedo*)

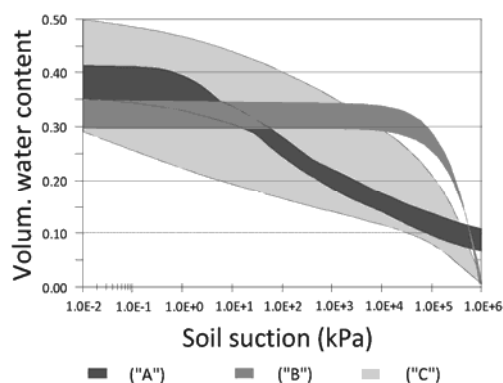

Figure 2. Proposed WRC ranges for the Huallaga River Watershed: A-sands; B-clays; C-silty-clays (from *Carrillo-Gil & Carrillo-Acevedo*)

Reducing the scale of investigation, *Sugii et al.* (Japan) analyse a mixed experimental and numerical approach to study the retention and the conductivity properties of an upper unsaturated sandy layer at the site scale, with an infiltrometer scheme typically coming from the field of hydrology. The Authors suggest that simple approximations for the pressure field and moisture distribution upon infiltration may be sufficient to get reasonable estimates for the unknown variables, provided suction is measured at a convenient depth. The comparison between the field data and the results of a laboratory model, replicating the experimental procedure in situ, shows that while the two hydraulic conductivity functions compare well, WRC estimates present significant differences, possibly coming from air entrapment effects.

The latter observation suggests that characterising the hydraulic properties of unsaturated soils still presents open issues, under different viewpoints. On the one hand, faster experimental procedures are sought, in order to allow for reasonable costs – especially in terms of time – of experimental tests. On the other hand, proper characterisation of the hydraulic properties of unsaturated soils need correct interpretation of the multiphase flow process promoted by the different experimental procedures.

For most soils, the determination of retention properties on the whole range of possible suctions usually requires a combination of different experimental techniques, possibly controlling different exchange mechanisms. *Maček et al.* (Slovenia) combine data from two commercial equipment, to investigate the drying branch of the WRC of different soils. The WRC data are derived from tensiometer readings in an evaporation device for low suctions ( $0 \div 0.2$  MPa), and from relative humidity in the high suction range ( $>1$  MPa), by means of a dew-point potentiometer. By extrapolating the calibration range of the evaporation apparatus, they show how the two data sets may provide a reasonable picture of the whole drying branch of the WRC.

*Reis et al.* (Brazil) discuss how the experimental determination of the drying branch of the WRC can be speeded up by imposing suction with a small commercial centrifuge, carefully enhanced for WRC testing. Although the original idea dates back more than one century, still the procedure is not common in unsaturated soil testing, and it deserves further attention. In the equipment described by the Authors, the equivalent suction can be controlled either by changing the angular velocity of the centrifuge, or by increasing the lever arm of at constant rotational speed. Four samples could be tested at the same time, after careful assembly and saturation of the set-up. Results obtained in the small centrifuge compare well with data from more traditional testing procedures on both undisturbed and remoulded samples of clayey silty sand in the range  $0 \div 0.9$  MPa, even though small differences between results of the various techniques may be observed, especially in the low suction range. The evidence suggests that careful inspection of the influence of volume changes on the state variables during testing is necessary to interpret correctly data from different testing methodologies. Also, data obtained in the laboratory are seldom the result of the behaviour of the soil samples alone, but they are affected by the whole experimental set-up, materials and procedures adopted. The work presented by *Nishimura* (Japan), in which a micro-porous membrane is tested in a pressure plate apparatus on different soil types, confirms the latter observation.

Innovative and promising techniques for unsaturated soils now try to exploit electromagnetic properties of multiphase mixtures. *Toll et al.* (UK) discuss an efficient fast multi-electrode resistivity system, and present a new combined sensor for suction and water content (Fig. 3), consisting in a coiled TDR, which can be used in conjunction with a high capacity tensiometer for simultaneous measurement of water content and pore water pressure.

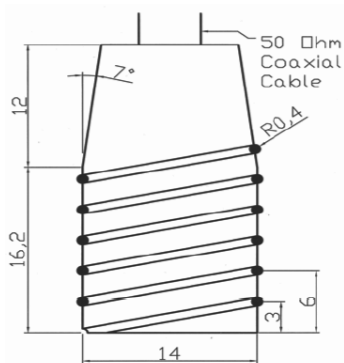

Figure 3. Schematic of tensiometer housing and coiled TDR - dimensions in mm (from Toll *et al.*)

The multi-electrode resistivity system is combined with automatic multiplexing to exploit a large number of electrodes. To prevent electrode polarization short pulses and reverse polarity readings are adopted. Calibration tests demonstrate that the proposed equipment gives a maximum error of less than 1% on resistance. The system was used to investigate both drying and wetting of sandy clay samples from a trial embankment. A very well defined resistivity-water content relationship was obtained, with high correlation coefficients, confirming potentialities of this technique both in the laboratory and in the field.

The new sensor proposed in the paper, combining suction and water content measurement in a single probe, appears extremely promising for accurate simultaneous monitoring of the two variables, at least in the laboratory. Provided the interpretation of the data from coiled TDR properly accounted for the geometry of measurement scheme, the new device shows an accuracy for water content determination of  $\pm(0.047 \div 0.075)$ , already by means of a theoretical model based on mixture theory, in the absence of direct experimental calibration. The new probe was tested on different soils, ranging from sand to clay and organic soil, and performed well in most cases against conventional 3 prong TDR device.

It is worthwhile remarking that most of previous experimental data do not allow for an exhaustive picture of the whole WR domain. On the one hand, still most data are collected along drying paths only. On the other hand, for those soils which undergo significant volume change during drying and wetting, the typical data collected just represent a series of pictures of water contents at different void ratios. Information on void ratio at subsequent stages is seldom provided, hence hindering to a certain extent a comprehensive interpretation of the retention behaviour, and generalisation of the laboratory information to different hydraulic paths and history.

Dependence of the WR behaviour on initial state and hydraulic history is discussed by Mendes & Toll (UK) on remoulded sample of sandy clay of low plasticity. Their results confirm that the WR domain is affected by mechanical state parameters especially at low suction values, where the dominant retention mechanism is capillarity. At decreasing water content, the amount of water retained inside the soil mostly depends on the physico-chemical characteristics of the solid phase, and tends to become independent from the actual void ratio, as recently discussed by various authors.

At high water ratios suction changes affect significantly both the hydraulic state and the mechanical state of the soil, depending on the soil fabric and on the shrinkage-swelling properties of the soil. Fredlund & Zhang (Canada) suggest to assist the interpretation of water retention data from conventional equipment – which do not provide usually any information on void ratio – with simple results from conventional shrinkage curves. Careful choice of size and aspect ratio should prevent cracking of the sample during the

test, thus allowing to associate a value of void ratio to each suction-water content state. Current degree of saturation can be determined from the pair of data void ratio - water content, hence allowing re-writing the drying branch of the water retention curve in terms of degree of saturation as a function of void ratio too. The procedure suggested may help in better discriminating between changes in water ratio due to retention mechanisms from water expulsion due to changing void ratio, but its applicability is limited to the drying branch of the water retention domain. Also, the consequences of stress state cannot be accounted for, as no stress is applied to the drying sample. The results can therefore be up scaled to the field only for the upper horizon of the soil, where the effects of stress could be disregarded.

In spite of all the efforts currently dedicated to suggest new fast and reliable techniques for characterising the water retention properties of unsaturated soils, it is worthwhile observing that data from most experimental techniques are the result of multiphase flow processes, and that some aspects of these processes are not fully understood yet.

The work by Mukunoki & Mikami (Japan) includes highlights on one of these aspects, which is the dependence of the retention properties of porous media on the rate of convective flux. The study presented by the Authors was aimed at understanding the mechanism of light non-aqueous phase liquid (LNAPL) migration in sandy soils. To this aim a new testing apparatus was conceived, in which fluid is injected in the sample and the flow is tracked by a micro-focused X-ray computed tomography scanner (MXCT), as schematically depicted in Fig. 4. Both inlet and outlet pressure were measured, as well as the outflowing mass of fluid. The distribution of the fluid phases was analysed taking into account connectivity of the 3D pore structure in the elaboration of MXCT data (Fig. 5). The results show that the distribution of the fluid phases in the soil pore structure following the induced flow will depend on the injection rate. The reason for this dependency is that the local path followed by the injected fluid will change depending on convective (Darcy) velocity, hence on current hydraulic conductivity and hydraulic gradient, kinematic viscosity and interfacial tension.

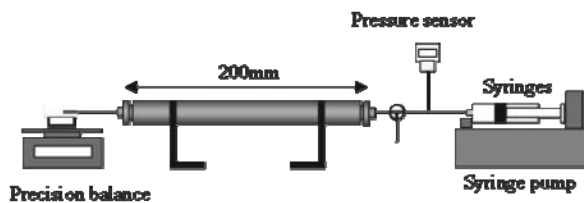

Figure 4. Schematic of MXCT fluid injection testing set-up (from Mukunoki & Mikami)

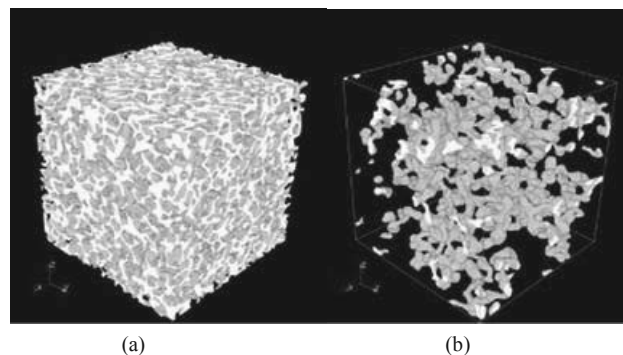

Figure 5. MXCT images of (a) pore structure, and (b) LNAPL residual distribution (from Mukunoki & Mikami)

### 3 TESTING AND MODELLING THE MECHANICAL BEHAVIOUR

A lot of effort in the field of unsaturated soil mechanics has been devoted in the past to experimental investigation and theoretical modelling of the mechanical behaviour of unsaturated soils subjected to suction changes. This may be the reason why the contributions dealing with conventional aspects of the mechanical behaviour of unsaturated soils are few, and mostly addressed to specific soils under a limited variety of stress-paths.

The attention is mostly focused on materials used in compacted earth constructions, either to evaluate the performance of the as-compacted materials, or the effects of weathering and of improvement techniques. These contributions are mostly motivated by the need for assessing existing and new embankments under seasonal change of moisture content, and for increasing their resilience to extreme events. More attention is devoted to the investigation of the mechanical behaviour of unsaturated soils under cyclic and dynamic loading, which typically characterise the working conditions of embankments. Moreover, where the seismic risk is high, a necessity is felt for proper criteria to assess embankments after relevant seismic events, which may impair functionality under normal working conditions.

#### 3.1 Compacted natural and treated soils in earth construction

*Bai et al.* (China) concentrated their attention on the behaviour of a compacted loess like silt. Their study focuses on the influence of compaction water content and compaction energy on the compressibility of the soil. The data show that the compressibility of this soil increases with water content for a given energy. If the compaction energy is changed at a given water content, the minimum compressibility is found to correspond to the density for which the given water content represents the optimum.

Degradation due to wetting and drying on Pierre Shale is analysed by *Schaefer & Birchmier* (USA), motivated by frequent slope instabilities observed in this formation and extensive problems documented in the construction of dams. The residual shear strength was analysed by means of ring shear apparatus after drying and wetting weathering cycles. Evaluation of physical properties, chemical analysis and Scanning Electron Microscope images completed the evaluation of the effects of weathering. The Authors observed minor changes in mineralogy, but significant changes in the fabric of the material, while no definite conclusions could be reached for residual strength.

To stabilise compacted soils and to reduce the effects of weathering, improvement techniques may be implemented. *Mavroulidou et al.* (UK) investigate the behaviour of lime treated London clay, for use in stabilisation of roads and pavements, as well as a technique to increase workability during construction. Samples of lime treated London Clay were prepared in the laboratory by static compaction after mixing powder London clay and lime. After curing, with two different techniques, the samples were tested in a triaxial equipment under different controlled saturation conditions. A number of triaxial tests were carried out to assess the effect of lime on the hydro mechanical properties of statically compacted London Clay and lime-treated London Clay samples. Filter paper was used to study the retention behaviour of both the original and the treated soil, in the suction range of interest. In view of the use of the improved material in earth construction, the experimental results suggest that a limited amount of lime could be sufficient to stabilise the soil. The solution is considered preferable to higher amounts of lime, as increasing the lime would decrease the ductility of the soil.

#### 3.2 Response of unsaturated soils to elastic waves

Three contributions analyse the response of unsaturated soils to elastic waves, both as a mean of analysing the state of the soil, and to predict the mechanical behaviour under dynamic loads.

*Byun et al.* (Korea) use compression and shear waves to analyse the response of a sand and a silty-sand as a function of the degree of saturation. A common pressure plate extractor was modified to apply axial stress and measure elastic wave velocity. Bender elements and piezo-electric disk were mounted in the cell to this aim. The results seem to suggest that for sand the influence of stress level on the elastic stiffness is predominant with respect to the effect of suction. The latter can be better appreciated for the soil containing a higher amount of fines.

*Georgetti et al.* (Brazil) analyse a compacted clayey sand in the whole range of shear strains, from small strain to failure. Multistage triaxial tests were performed on unsaturated samples kept at constant water content. Suction was measured during the tests by means of axis translation technique. Tests were performed with bender elements to investigate the influence of suction and confining stress on small strain modulus. Also in this case, the small strain modulus appears to be influenced more by confining stress rather than suction, at least in the range investigated. As expected, the effect of suction tends to become more relevant at decreasing confining stress. Nonetheless this result can not be considered a general conclusion, as in this case the soil was investigated in a range of suction where the degree of saturation – hence the state of the soil – hardly changes, keeping around 60.

Dynamic properties of unsaturated sandy silt are studied in a broader sense by *Hoyos et al.* (USA) with a proximator-based resonant column device. The device developed by the Authors includes bender elements and allows for testing soils under controlled suction conditions by means of axis-translation technique. Stiffness and damping are investigated, the latter after careful inspection of the influence of suction on the frequency response curves (Fig.6).

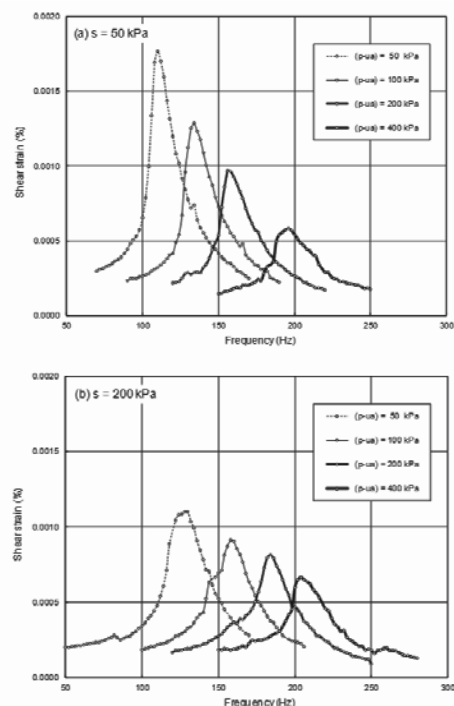

Figure 6. Frequency response curves from SM soil at different net confinement and suction states: (a)  $s = 50$  kPa; and (b)  $s = 200$  kPa (from *Hoyos et al.*)

The response of the soil is not symmetric with respect to the resonant frequency, which complicates the interpretation of the data in terms of material damping. The logarithmic decay curves were used to the scope. The results confirm once more that suction affects the resonant frequency although to a lesser extent than confining stress. As expected, equivalent viscous damping decreases at increasing suction.

### 3.3 Theoretical and numerical modelling

While recent experimental efforts are dedicated to dynamic and weathering behaviour, still modelling efforts are mostly concentrated on developing constitutive laws for unsaturated soil behaviour under static loads, especially in view of engineering applications. Still a gap appears separating advanced modelling frameworks from simpler laws, which are suggested for straightforward application in the practice.

*Vázquez et al.* (Spain) present a simplified model to predict collapse upon wetting, based on oedometer test results on a sandy-silty clay. They summarise their experimental results in terms of an Instability Index, depending on applied vertical stress, giving the amount of expected collapse as a function initial suction and suction change. Although simplified, the models depends on two parameters only, and can thus be suggested for preliminary evaluation of collapse strain when a one-dimensional geometric scheme can be applied in the field.

*Zhao et al.* (China) discuss an interesting theoretical aspect of unsaturated soil modelling approaches. Starting from the observation that the critical state concept has been acting as a cornerstone in the development of models for saturated soils, they investigate the constraints leading to a thermodynamic consistent definition of critical state for unsaturated conditions. The Authors point out that for unsaturated soils variables including the hydraulic state concur to a proper definition of critical state. A thermodynamically consistent steady state is reached when all the relevant static and kinematic variables, including fluid pressures and volume fractions, reach their asymptotic values, while only further deviatoric strain is observed. Interestingly, they remind that critical state may not be unique, depending on soil fabric, as already observed for saturated soils with a dominant initial structure.

Advanced models, accounting for fabric, weathering, degradation usually require a numerical implementation for their evaluation, even before they are adopted to analyse boundary value problems. *Fathalikhani & Gatmiri* (Iran) present a coupled thermo-hydro-mechanical numerical formulation of a model based on damage theory, developed to analyse the effects of excavation in host geological barriers. In the model damage is treated as a tensorial variable, accounting for the directional crack pattern, while the effects of suction and temperature are assumed to be isotropic. The model, developed on both thermodynamic and micromechanical concepts, is evaluated on a set of literature experimental data on a small scale model of unsaturated bentonite, subjected to a heating and a following relaxation phase. The consequences of suction and temperature changes on damage are investigated during heating and in the relaxation phase. The work highlights once more that interpreting the multiphysics behaviour of soils is far from being straightforward, and that even laboratory tests should be careful analysed as boundary value problems at a small scale.

Following this line, *Kawai et al.* (Japan) present a Finite Element model of compaction, using an elastic-plastic model for unsaturated soils. A typical compaction stress history is imposed, including the loading and the unloading stages. Void ratio as well as suction are tracked along the stress path. The simulation highlight that the state which is generally defined as “as-compacted”, is the result not only of the loading stage, but also of the following unloading path.

### 3.4 Modelling structures and infrastructures

The dependence of the as compacted state on compaction history complicates the application of models for compacted soils to full scale problems, as the paper by *Droniuc* (France) suggests. In the latter contribution, a Finite Element analysis of a model embankment made of fine grained soil is presented, and the numerical results are compared to experimental measurements from sensors installed in the model embankment. The Author points out that, besides the choice of a proper hydro mechanical model for the compacted soil, the analysis of an embankment requires a careful investigation of the initial and the boundary conditions. Swelling and shrinkage strains promoted by soil-atmosphere interaction affect the state of the material after compaction, and the heterogeneous profile of suction and water content result in a heterogeneous response of the system to hydro mechanical loads.

*Sakai & Nakano* (Japan) present a preliminary study on the effects of compaction on the dynamic performance of embankments, motivated by design approach moving towards a performance based concept in high seismic risk countries. Samples of sandy materials, having different grain size distributions, were compacted to different relative compaction degrees, and subjected to constant water content test in a triaxial apparatus. The results show that the density achieved during compaction affects the liquefaction potential of the soil. The experimental data are used to calibrate the model used to perform preliminary analyses of the response of an ideal embankment under seismic action.

*Heyerdahl et al.* (Norway) introduce another complicating feature in the assessment of infrastructures. Typically, a consistent part of railway embankments are now about 100 years old. In spite of strengthening part of them with modern criteria in recent years, still many of them are still working under conditions which follow their original design. Prolonged rainfall threaten the serviceability of the infrastructure system, by inducing widespread damage of the embankments. In their contribution the Authors provide an overview of damage mechanisms, trying to classify the possible sources of instability. Inadequate performance of culverts, water loads from flooding and slope instability promoted by rainfall infiltration are typically recognised as the main threatening processes. The analysis of one case history, presented in the second part of the paper, confirms that assessing an existing structure, without detailed knowledge of its hydro mechanical state and history, may be problematic, and that exhaustive indication for reliable assessment may not be obtained.

As a whole, it seems that most issues related to the assessment of existing structures and infrastructures concern possible climate changes. In the contribution by *Makki et al.* (France) the effect of differential settlements on masonry building due to shrinkage promoted by extreme drought is investigated, both on a prototype model and numerically (Fig. 7). In the experimental test, the prototype was supported by jacks, which were selectively removed to simulate differential settlements. A 3D refined model of the masonry construction reproduced well the observed displacements, and allowed evaluating the structural behaviour of the structure under possible action of drought.

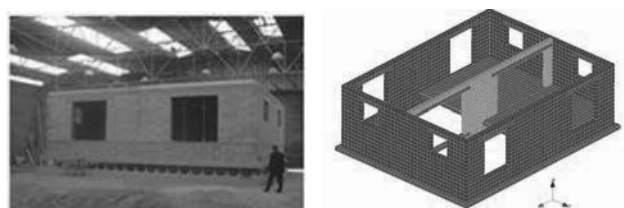

Figure 7. Experimental masonry prototype and 3D numerical model (from *Makki et al.*)

#### 4 EFFECTS OF CLIMATE AND VEGETATION

A consistent number of papers are being published in recent years presenting attempts to evaluate the consequences of increasingly severe climatic conditions. This conference is not an exception, as nearly one third of the papers are broadly related to issues related to this theme.

*Liu & Yasufuku* (Japan) present a self-watering system of new conception to support superficial vegetation in arid climate. The basic idea is to bury clayey inclusions in coarser soil to exploit their retention properties to store water. The proposed system should be able to regulate the capillary fringe, and reduce evaporation, in turn helping in preventing from salinization. A model test, numerical simulation and design specifications are presented in the contribution. The performance of the proposed system will depend mostly on water retention properties, hydraulic conductivity of the soil, vegetation activity and fresh water availability, but also on the geometrical configuration of the water trap.

*Mitchell* (Australia) investigates expansive soil movements under climatic impact, for vegetated and non-vegetated areas. The aim of the study is to evaluate the resilience of existing and new structures, and to provide useful revision guidelines for foundation design standards. A simple one-dimensional model averaged with depth is adopted to calculate heave and settlement of expansive soil, subjected to the moisture excess or deficiency predicted for the next half century, summarised by means of a simple moisture index.

*Hemmati & Modaressi* (France) analyse the stability of slopes under infiltration accounting for vegetation. In their analysis, performed with the aid of a finite element model, both infiltration and evapotranspiration are explicitly accounted for. The latter is described by means of an empirical function giving the evapotranspiration flux as a function of root density and depth, based on potential evapotranspiration. The model allows a preliminary evaluation of the effects of vegetation on slope stability, and shows that these depend also on the retention properties of the vegetated soil.

In all previous contributions the effect of vegetation is accounted for by means of previous literature relationships, coming either from agronomy or hydrology. Although these relationships usually prove to be sufficient for a preliminary description of soil-vegetation-atmosphere interaction, they disregard the role played by the retention and transport properties of the soil. The contribution by *Ng et al.* (Hong Kong) is intended to provide an insight in time evolution of suction resulting from vegetation activity. A laboratory set up was designed and manufactured to compare the evolution of suction and water content in vegetated soil horizon with the same bare soil. Two different types of vegetation were investigated, and their effect on energy distribution was evaluated. The environmental conditions were carefully controlled, and suction and water content profiles were recorded at increasing depth. As the soil state in turn affects the root growth, the root system was characterised after the test. The results allowed quantifying the effects of the two different types of vegetation on the soil suction profile, both in terms of interception and evapo-transpiration.

#### 5 SWELLING, SHRINKAGE AND CRACKING

In fine grained soils, multiphysics processes, starting from soil-atmosphere interaction, are accompanied by relevant volume changes, often ending in cracking and degradation. This aspect of the mechanical behaviour is a common issue of various applications in geotechnical engineering, including foundations, liners and mine tailings, to which some of the contributions presented to this session refer.

*Adem & Vanapalli* (Canada) discuss a simple approach for vertical displacements of expansive soils. The approach is based on a simple suction-strain relationship, and can be used to

predict vertical displacements promoted by suction changes in a one-dimensional scheme. The case of a residential site in the city of Regina, located on a highly expansive clay deposit, is described to suggest how the model can be applied. Suction changes profile were calculated by means of a numerical analysis in which the climatic history during one year was imposed. As the stiffness is assumed to be a function of the degree of saturation, hysteretic water retention behaviour will give different stiffness along drying and wetting path. The latter feature is confirmed among others by *Ejjaouani et al.* (Maroc), who present experimental data of a wetting and drying cycle on an expansive clay, and discuss possible source of non-reversible volume change.

*Stanciu et al.* (Romania) analyse cement stabilization to reduce the swelling and shrinkage potential, as a countermeasure against potential structural damage of structures founded on expansive clay. Comparing different active clays, the Authors propose a unified swelling classification chart, based on grain size distribution, liquid limit, plasticity index and activity of the clay. With reference to this comprehensive classification, the beneficial stabilising effect of different cement types is evaluated.

As a consequence of swelling and shrinkage, cracking may occur in active soils. The issue is of relevant interest for many engineering systems, although cracking occurrence and crack patterns are still difficult to be predicted and characterised.

*Auvray et al.* (France) present a device to analyse cracking evolution as a function of the hydraulic state. The soil investigated is an active mixture of silt and bentonite. Samples with a diameter to height ratio of about 5 were prepared by static compaction and left evaporating in a controlled climatic chamber. The height and the mass of the samples were recorded, together with the crack pattern, which was tracked by photographic imaging. Three samples were analysed during drying. In spite of similar initial conditions and similar vertical strain, significant differences in the crack pattern were observed (Fig. 8). The crack area was found to be higher for the sample that experienced lower lateral shrinkage, while it decreases at decreasing lateral constraint. Although the result is consistent, no reason for different behaviour is evident, as the boundary conditions were identical for the three samples. Nonetheless, it can be observed that cracking is a strongly localised mechanical processes, hence it is dominated by local heterogeneity which may be responsible for different cracking patterns.

More systematic cracking development and evolution were observed by *Avila et al.* (Colombia), who specifically designed the moulds in order to force repeatable crack pattern. The Authors discuss the stress state in the sample subjected to drying shrinkage, highlighting the role of boundary conditions on the overall behaviour of the soil. For the simple geometrical scheme adopted, the position and the sequence of cracks could be predicted based on a careful simplified stress analysis.

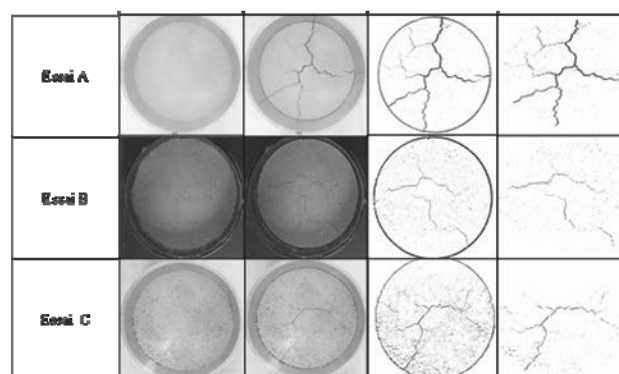

Figure 8. Surface analysis of the crack pattern upon drying on three theoretical identical samples (from *Auvray et al.*)

Sedimentation, consolidation and drying by evaporation are the processes of interest in impoundment of mine tailing containing fine particles. The contribution of *MacRobert* (South Africa) focuses on the drying behaviour of platinum tailings subjected to one year evaporation. The Author observes that the effects of natural drying in such tailings hardly reached 1m depth, and that drying of the upper layer prevented further suction development in the lower part of the tailings for a long time. Once more, the contribution confirms that drying is a complicated process, ruled by both the forcing conditions at the boundary and the hydraulic properties of the material.

*Bajwa & Simms* (Canada) discuss the evolution of the microstructure of oil sand fine tailings by means of scanning electron microscopy and mercury intrusion porosimetry, to better understand the interplay role of desiccation and consolidation. Polymer amended tailings were investigated to try to optimise tailing operation in oil sands. The behaviour pattern turns out to be similar to that of active clays, and drying was found to be more effective in changing the fabric of the oil sand than the added polymer.

While drying is the most relevant process for mine tailing, wetting dominates the performance of liners in landfill barriers. *Siemens et al.* (Canada) discuss from a theoretical viewpoint the beneficial effect of confining stress in transient hydration of geosynthetic clay liners (GCL), which enhance the retaining properties of the GCL, in turn increasing its hydration rate.

## 6 FINAL REMARKS

This report tackled briefly those aspects of unsaturated soil mechanics which were suggested by the contributions submitted to the conference. As such, it is not a comprehensive summary of recent developments. Yet, it provides a broad overview on those aspect which are perceived to be of relevant interest in a present and future perspective.

The overview suggests that unsaturated soil mechanics is still considered as a fundamental branch of soil mechanics, more than a body of knowledge able to provide widely accepted answers to geotechnical design. The most innovative contributions concern experimental set up at different scales. The most challenging open issues seem to be related to existing infrastructures, requiring reliable criteria for their assessment.

## 7 PAPERS SUBMITTED TO THE SESSION

Adem H.H., Vanapalli S.K.. 2013. A simple approach for predicting vertical movements of expansive soils using the mechanics of unsaturated soils. *Proc. of the 18th ICSMGE, Paris.*

Auvray R., Rosin-Paumier S., Abdallah A., Masrouri F. 2013. Etude de l'impact de l'hygrométrie sur la fissuration d'un sol gonflant. *Proc. of the 18th ICSMGE, Paris.*

Ávila G., Ledesma A., Loret A. 2013. One-dimensional cracking model in clayey soils. *Proc. of the 18th ICSMGE, Paris.*

Bai X., Yang J., Ma F., Yang J. 2013. Experimental study on effect of initial moisture content of compressive property of compacted loess like silt. *Proc. of the 18th ICSMGE, Paris.*

Bajwa T., Simms P. 2013. Evolution of microstructure during desiccation of oil sands mature fine tailings. *Proc. of the 18th ICSMGE, Paris.*

Byun Y.H., Lee J.S., Cho S.H., Yoon H.K. 2013. Evaluation of void ratio and elastic modulus of unsaturated soil using elastic waves. *Proc. of the 18th ICSMGE, Paris.*

Carrillo-Gil A., Carrillo-Acevedo A. 2013. Evaluation curves SWCC for tropical Peruvian soils. *Proc. of the 18th ICSMGE, Paris.*

Droniuc N. 2013. Étude par la methode des éléments finis du comportement des remblais en sols fins compactés. *Proc. of the 18th ICSMGE, Paris.*

Ejjaouani H., Shakhirev V., Magnan J.P., Bensallam S. 2013. Comportement des sols gonflants lors de l'humidification et du séchage. *Proc. of the 18th ICSMGE, Paris.*

Fathalikhani M., Gatmiri B. 2013. Numerical study of damage in unsaturated bentonite with  $\theta$ -stock finite element code. *Proc. of the 18th ICSMGE, Paris.*

Fredlund D.G., Zhang F. 2013. Combination of shrinkage curve and soil-water characteristic curves for soils that undergo volume change as soil suction is increased. *Proc. of the 18th ICSMGE, Paris.*

Georgetti G.B., Vilar O.M., Rodrigues R.A. 2013. Small-strain shear modulus and shear strength of unsaturated clayey sand. *Proc. of the 18th ICSMGE, Paris.*

Hemmati S., Modaressi A. 2013. Etude de la stabilité des pentes non saturées sous les effets de l'infiltration prenant en compte la végétation. *Proc. of the 18th ICSMGE, Paris.*

Heyerdahl H., Høydal Ø., Nadim F., Kalsnes B.G. 2013. Rainfall-induced collapse of old railway embankments in Norway. *Proc. of the 18th ICSMGE, Paris.*

Hoyos L.R., Cruz J.A., Puppala A.J., Douglas W.A. Sueascún E.A. 2013. Dynamic shear modulus and damping of compacted silty sand via suction-controlled resonant column testing. *Proc. of the 18th ICSMGE, Paris.*

Kawai K., Iizuka A., Kanazawa S. 2013. Expression of mechanical characteristics in compacted soil with soil/water/air coupled F.E. simulation. *Proc. of the 18th ICSMGE, Paris.*

Liu Q., Yasufuku N. 2013. A geotechnical countermeasure for combating desertification. *Proc. of the 18th ICSMGE, Paris.*

Mac Robert C. 2013. Field capacity and moisture loss during active deposition on tailing dams. *Proc. of the 18th ICSMGE, Paris.*

Maček M., Smolar J., Petkovšek A. 2013. Extension of measurement range of dew-point potentiometer and evaporation method. *Proc. of the 18th ICSMGE, Paris.*

Makki L., Bourgeois E., Burlon S., Magnan J.-P., Duc M. 2013. Effet du retrait du sol sur une maison expérimentale. *Proc. of the 18th ICSMGE, Paris.*

Mavroulidou M., Zhang X., Kichou Z., Gunn M.J. 2013. Hydro-mechanical properties of lime-treated London clay. *Proc. of the 18th ICSMGE, Paris.*

Mendes J., Toll D.G. 2013. Influence of initial water content on the water retention behaviour of a sandy clay soil. *Proc. of the 18th ICSMGE, Paris.*

Mitchell P.W. 2013. Climate change effects on expansive soil movements. *Proc. of the 18th ICSMGE, Paris.*

Mukunoki T., Mikami K. 2013. Study on the mechanism of two-phase flow in porous media using X-ray CT image analysis. *Proc. of the 18th ICSMGE, Paris.*

Ng C.W.W., Leung A.K., Garg A., Woon K.X., Chu L.M., Hau, B.C.H. 2013. Soil suction induced by grass and tree in an atmospheric-controlled plant room. *Proc. of the 18th ICSMGE, Paris.*

Nishimura T. 2013. Application of micro-porous membrane technology for measurement of soil-water characteristic curve. *Proc. of the 18th ICSMGE, Paris.*

Reis R.M., Saboya F., Tibana S., Marciano C.R., Ribeiro A.B., Sterck W.N., Avanzi E.D. 2013. Determination of soil-water retention curve for a young residual soil using a small centrifuge. *Proc. of the 18th ICSMGE, Paris.*

Sakai T., Nakano M. 2013. Interpretation of the effect of compaction on the mechanical behaviour of embankment materials based on the soil skeleton structure concept. *Proc. of the 18th ICSMGE, Paris.*

Schaefer V.R., Birchmier M.A. 2013. Mechanisms of strength loss during wetting and drying of Pierre shale. *Proc. of the 18th ICSMGE, Paris.*

Siemens G.A., Take W.A., Rowe R.K., Brachman R. 2013. Effect of confining stress on the transient hydration of unsaturated GCLs. *Proc. of the 18th ICSMGE, Paris.*

Stanciu A., Aniculaesi M., Lungu I. 2013. Soil chart, new evaluation method of the swelling-shrinkage potential, applied to the Bahlui's clay stabilized with cement. *Proc. of the 18th ICSMGE, Paris.*

Sugii T., Yamada K., Asano N., Yamada Y. 2013. Measurement of unsaturated ground hydraulic properties using a dynamic state soil moisture distribution model. *Proc. of the 18th ICSMGE, Paris.*

Toll D.G., Hassan A.A., King J.M., Asquith J.D. 2013. New devices for water content measurement. *Proc. of the 18th ICSMGE, Paris.*

Vázquez M., Justo J.L., Durand P. 2013. A simplified model for collapse using suction controlled tests. *Proc. of the 18th ICSMGE, Paris.*

Zhao C.G., Li J., Cai G.Q., Liu Y. 2013. Critical state for unsaturated soils and steady state of thermodynamic process. *Proc. of the 18th ICSMGE, Paris.*